

BAR BENDET

PRODUCT DESIGN PORTFOLIO 2024



HI! I'M BAR BENDET

BARBENDET.COM

bendb985@newschool.edu

(201) 588-0275

PRODUCT DESIGN STUDENT

CLASS OF 2025

I am a Junior studying product design at Parsons School of Design. My design philosophy is to solve people's problems with distinctive, innovative, yet realistic designs with a clear intent of being a multi-functional solution. I strive and challenge myself to create solutions that are multidisciplinary, ambitious, but most importantly practical. I have a STEM-driven mindset and love to experiment with materials and techniques. I am eager to expand my knowledge and skillset through impactful projects.

WORK EXPERIENCE

RESEARCH ASSISTANT

at CIRCULAR ECONOMY MFG.

MAY 2023 - DEC 2023

As a part of the design team I ideated new products for rotational molding manufacturing, specifically kids' chairs.

TEACHER'S ASSISTANT

at ONE RIVER SCHOOL OF ART & DESIGN

JUNE 2019 - AUG 2021

Supported teachers with their art/design processes, and guided students, ages 3 to 18, to make art. Helped to manage administrative work, including customer service, inventory, social media, and content creation.

BRAND AMBASSADOR

at 7th HEAVEN CHOCOLATE INC.

MAY 2023 - PRESENT

Responsible for set-up, organization, and operation of the brand's booth at trade and consumer shows.

EDUCATION

AUG 2021 | PARSONS SCHOOL OF DESIGN | NEW YORK, NY

PRESENT

GPA: 3.96

Pursuing a Bachelor of Fine Arts in Product Design

LANGUAGES

english



hebrew



SKILLSET

concept drawing

prototyping

mock-ups

model-making

html/css

non-ferrous metalwork

sculpting

iterating

research

woodworking



**CHERRY
COAT RACK**

**TOY
TRAIN**

**NON-FERROUS
METAL WORKS**

**RING
FOR CLIENT**

**DUOGRIP KID'S
TOOTHBRUSH**

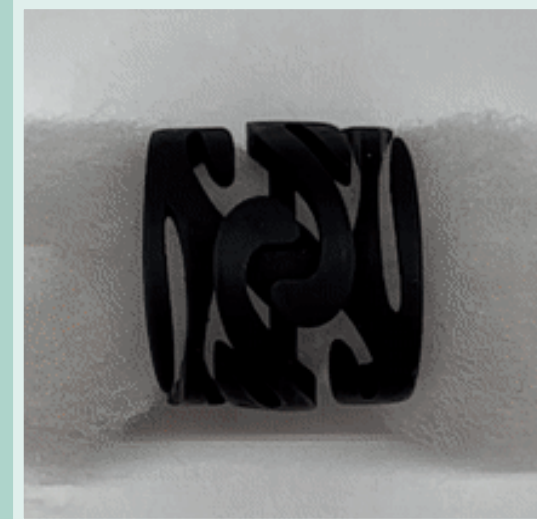

4

6

8

10

12

CHERRY COAT RACK

DEC 2022

Cherry Wood, 3D-Printed Wall Mounts

50 x 8 x 1 inches

PROJECT:

Make a coat rack for a small New York City apartment. Floor space is limited, and hallways are narrow. The apartment houses three students, lots of storage is needed.

MY APPROACH:

After measuring all the space available in the common area of the apartment, I decided that for a coat rack to fit it would need to be wall-mounted, rather than take up floor space.

With the wall space available, the challenge was to minimize the hallway space it would occupy. This led to the motion of pulling out the hooks when in use, and pushing them back when not.

On top of that, the profile of the coat rack would be the first thing visible from the apartment's entrance, so it needed to be visually appealing and functional.



COMING UP WITH THE DESIGN:

Finding a profile that matched the space was key for me to start the design process. The coat rack as a whole needed to be a statement piece when not in use, since the wall it is mounted on is tall and empty in a narrow hallway. I wanted a modern and young feel to the piece with warm undertones, to bring life to students' space. For maximum function, it needed to have as many working hooks as the space allowed. On the skillset aspect, I wanted to challenge myself to make a moving wooden piece of furniture.

MECHANISM:

The movement of the individual "hook" was tested through this model, where the angle was adjusted. The model revealed the type of curve that was needed in between the two rest positions, for smooth usage.

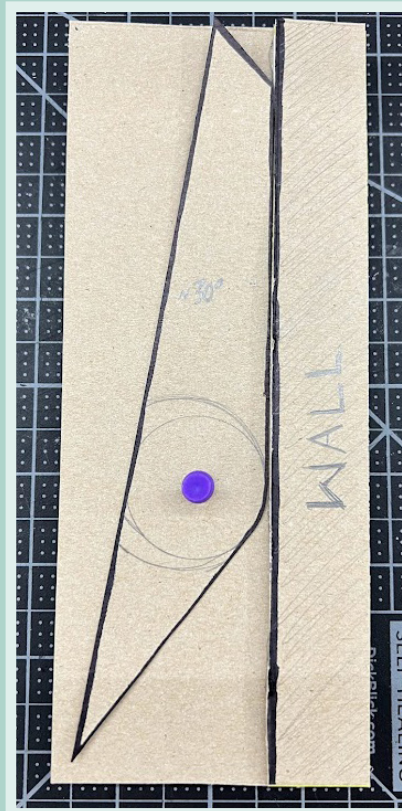
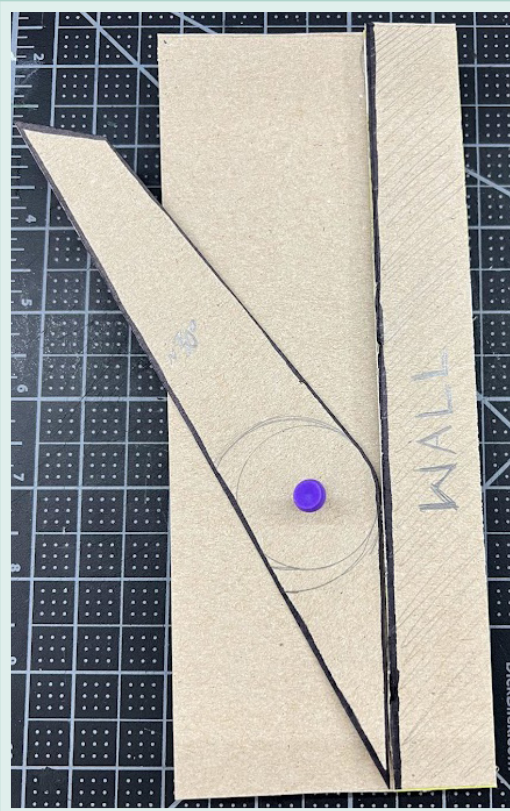

SOLIDWORKS, Keyshot, 3D Print

6 x 3 x 2 inches

PROJECT:

Design and print a toy that has multiple parts in an assembly in SOLIDWORKS.

Final presentation of the product needs to include production drawings for all the individual parts, as well as an exploded view with bill of materials.

MY APPROACH:

I grew up playing with toy trains, building things, and taking them apart, so I drew inspiration from all of these elements to create a train that could be taken apart and reassembled.

I wanted to challenge myself further by adding a motion element to the design, with the wheels being fully functional.

I took inspiration from the design language of wooden train toys made for toddlers, as well as streamlining designs, to create a train design that looks sleek and fun to play with.

The parts can be assembled in different orientations to create unique configurations of the train.

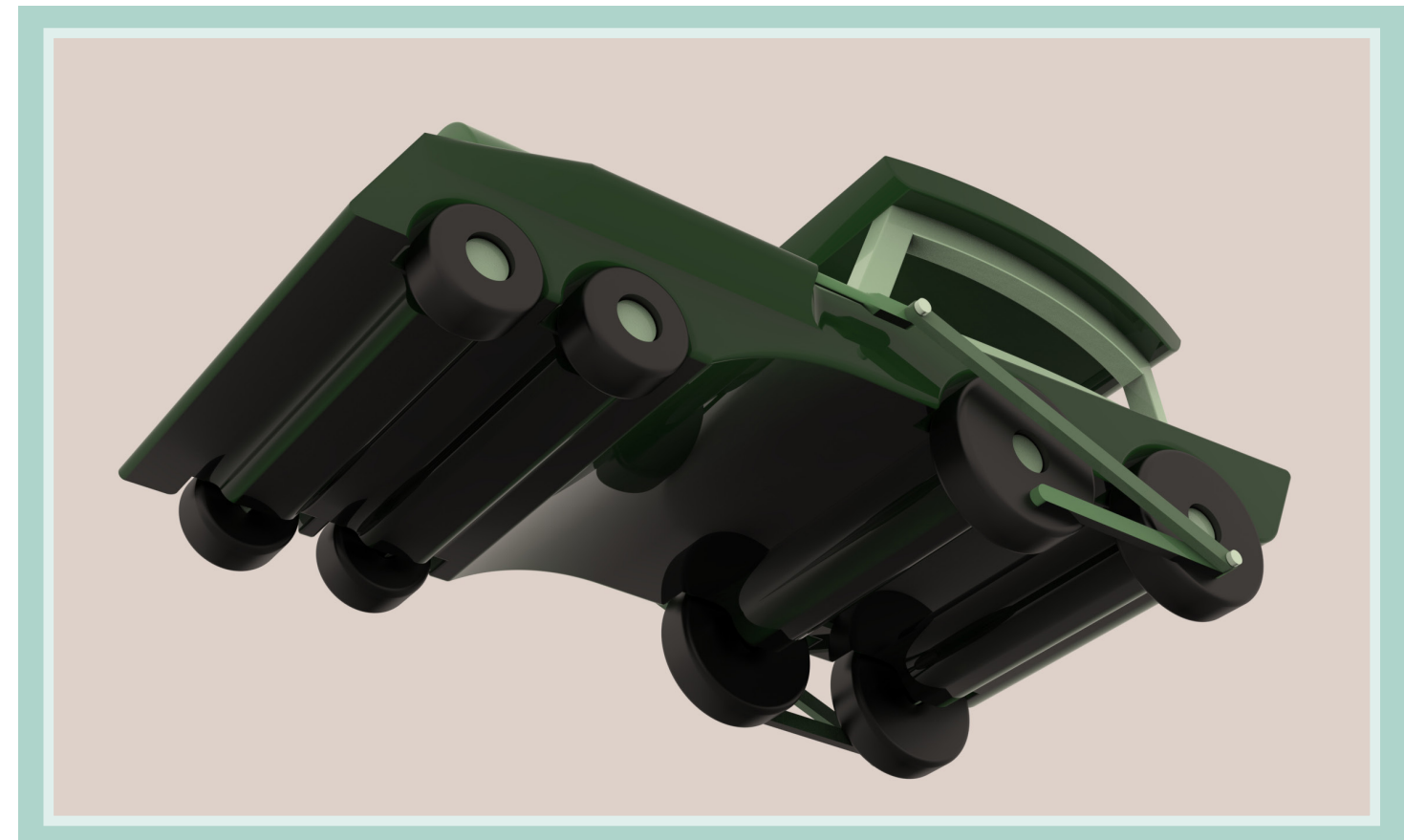
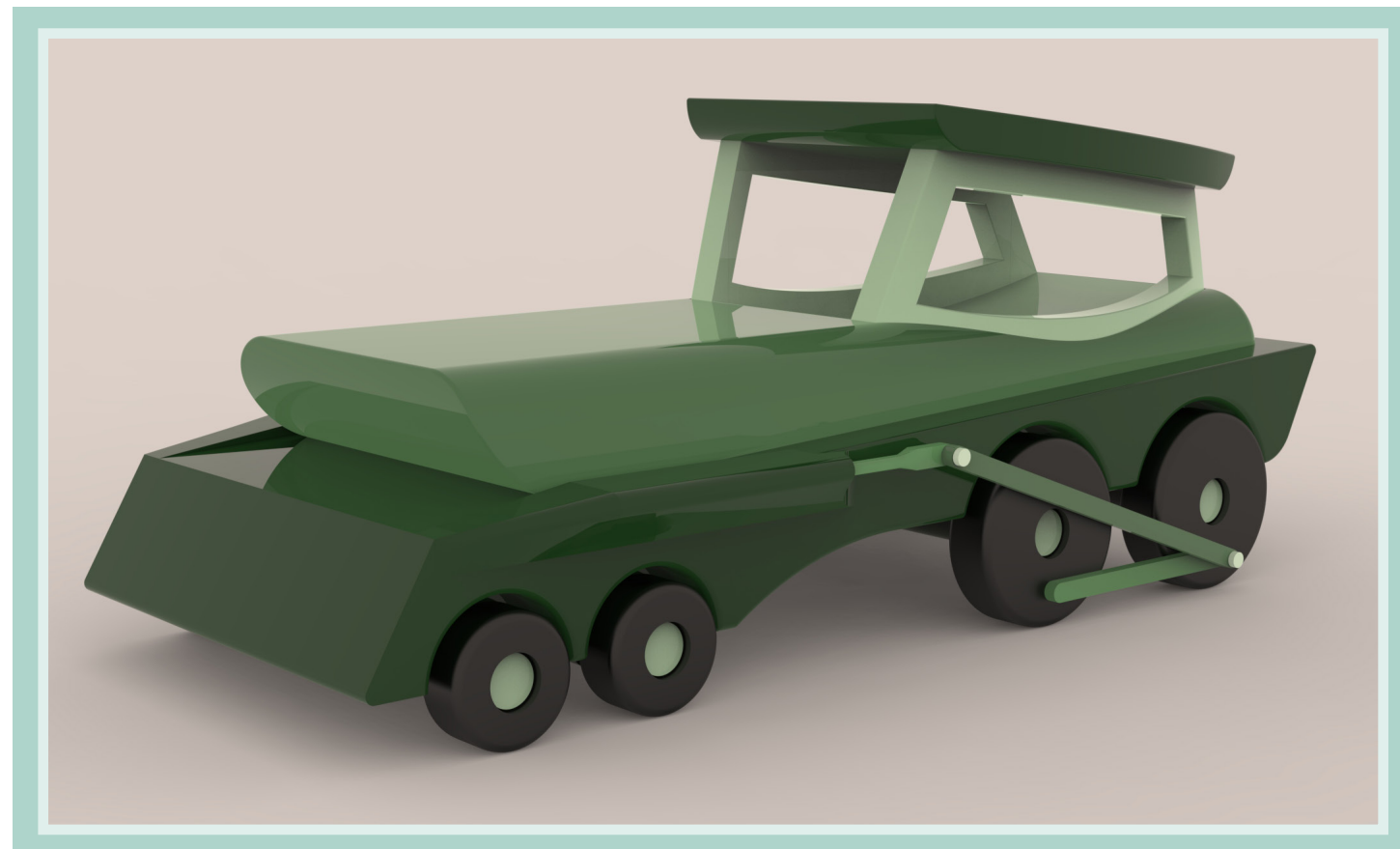

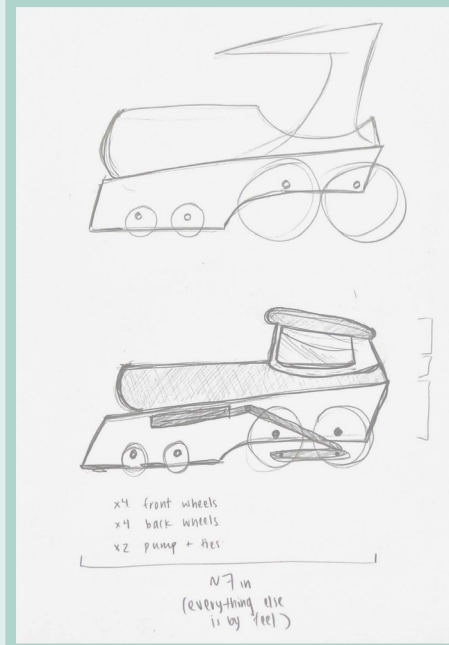
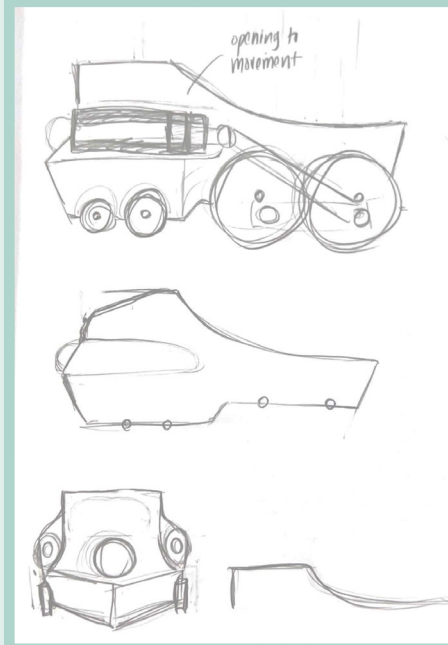

COMING UP WITH THE DESIGN:

I experimented with different ways to redesign the iconic wooden train look. I wanted this train to be more streamlined yet recognizable.

The different parts of the train (base, body, and cab) needed to have visual cues to show they come apart and come together.



THE PRINT:

Every measurement and tolerance in the CAD model was calculated to allow the design to work solely with friction fits.

The wheels had a separate tolerance calculation to allow them to be glued to the axle.

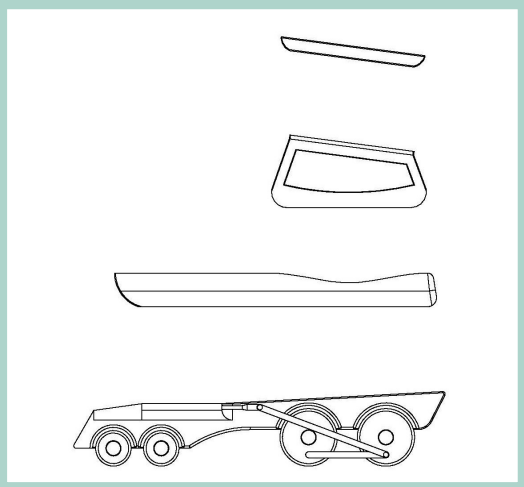
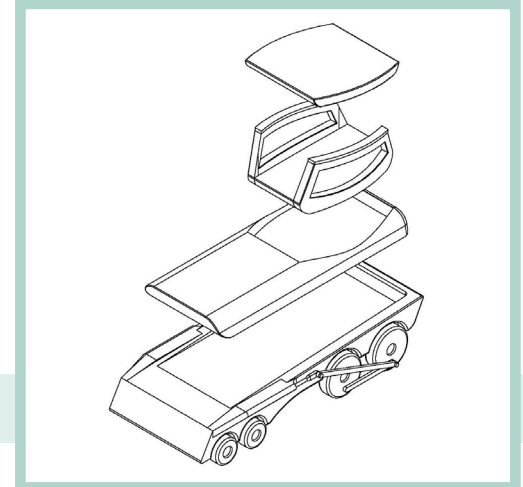
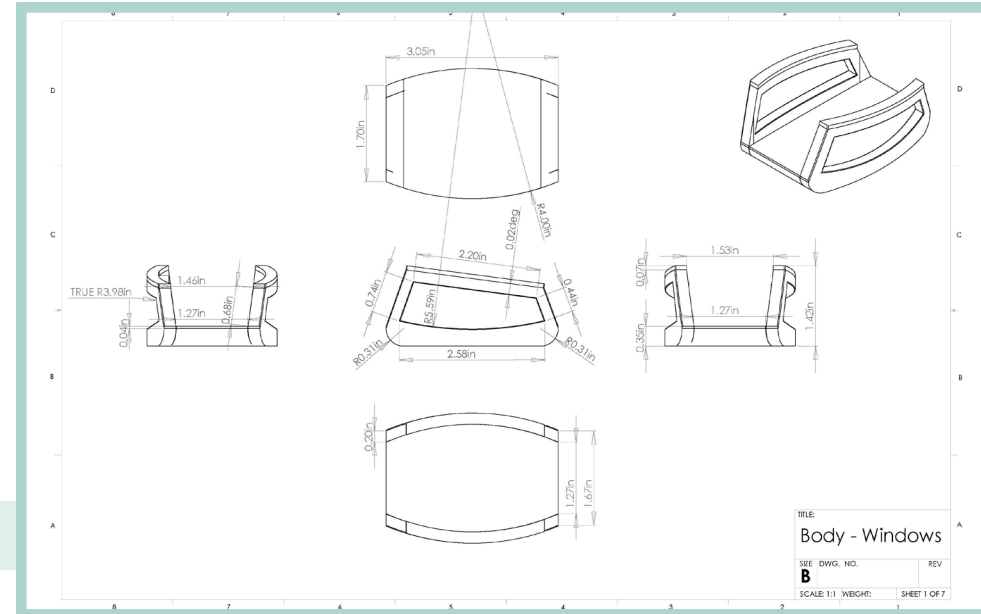
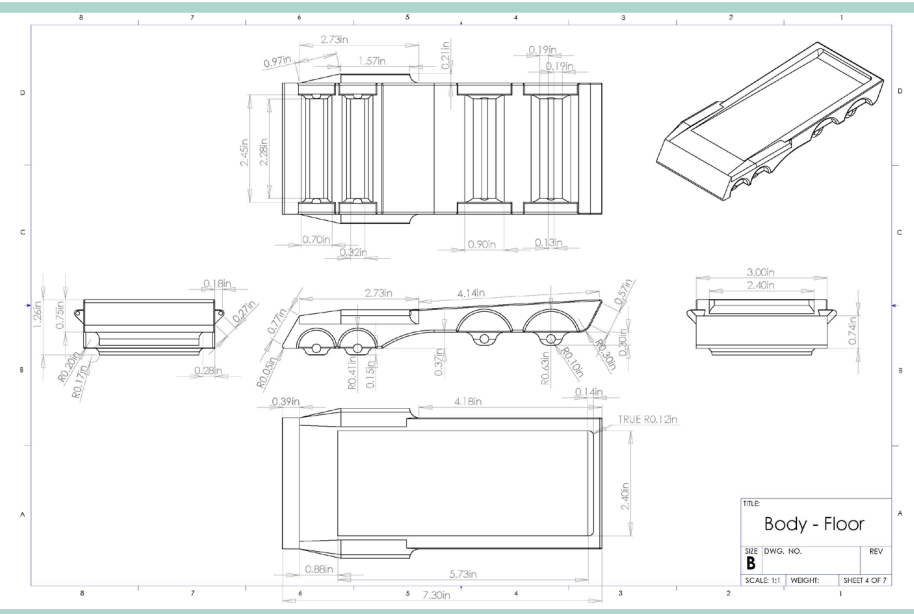
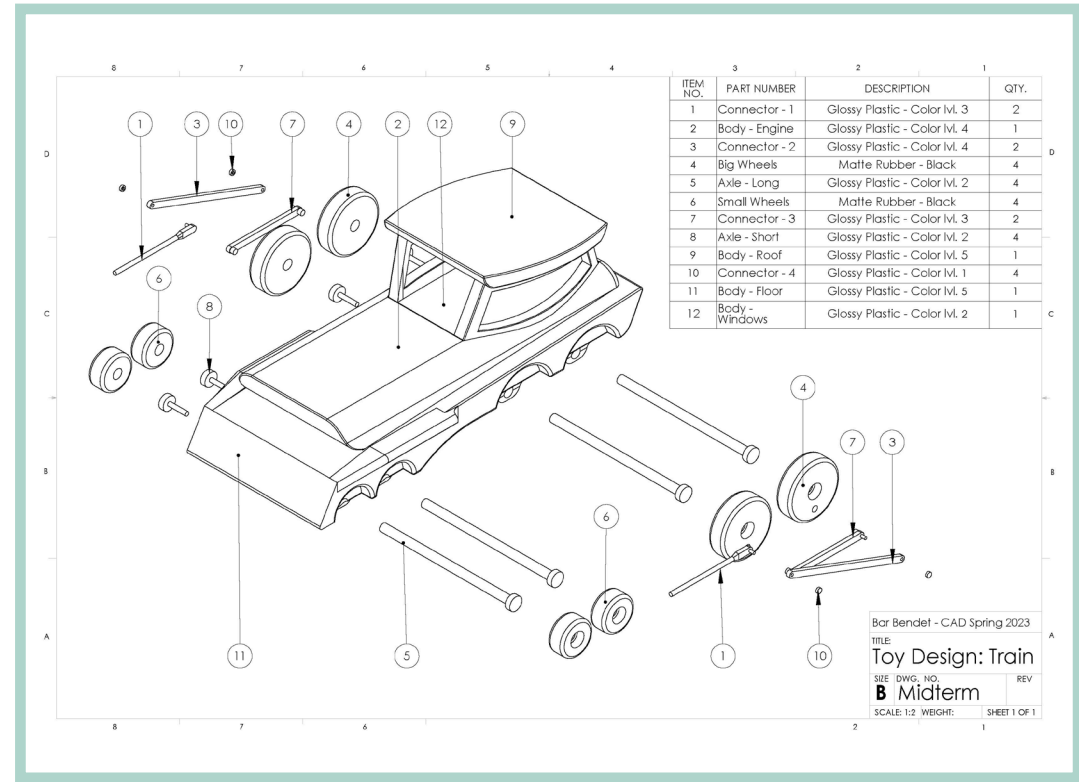

NON-FERROUS METAL WORKS

SEPT-DEC 2023

Brass and Copper

PROJECT:

Develop basic metal working skills and knowledge through six different projects, in the duration of three and a half months.

Material choices and gauges are limited, allowing for focus on skills/development.



MY APPROACH:

In every project I experimented with additional techniques and applications. I wanted to maximize the types of methods of metal working implemented. I concentrated on understanding the chemistry/physics behind the work, as these are deep interests of mine. I also wanted to create objects that could be used, rather than ones only for display (when the material allowed). Specifically with the jewelry, I wanted for the pieces to be something I could wear daily.





SET OF SPOONS:

The overall shape was inspired by Asian-style soup spoons, specifically with how the handle connects to the bowl. The curved end of the handle adds a more ergonomic grip.

With the use of a hydrolic press and annealing, I created the bowls and soldered them to the two parts of the handle: the thin bottom curve and sculpted rod.

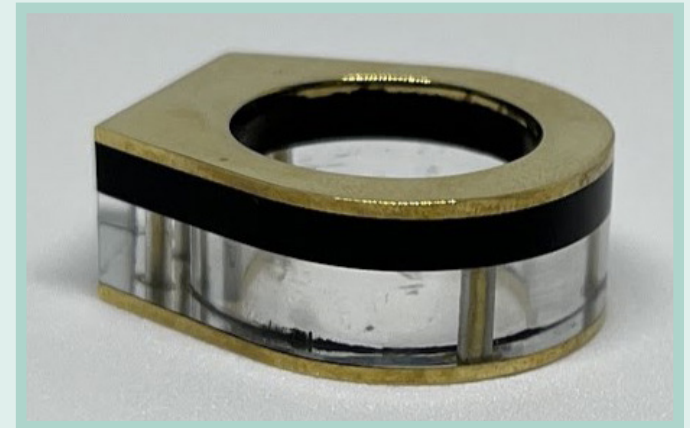

RIVET RING:

This ring was my first ever metalworking project. It has two pieces of acrylic, black and clear, layered between brass faces and connected with four invisible rivets. I wanted to show off the making process of the ring, so the rivets go through a clear acrylic, while the faces remain smooth.



CONTAINER:

I designed this container with the thought of making a shape that is not a standard cube/cylinder. On top of that, I wanted a uniform ratio between the lid and body to reflect the curvature of the fit. I used marriage of metals and sweat soldering to create the copper and brass connections. The liver of sulfur oxidation finish inside the container brings everything together elegantly.



RING FOR CLIENT

SEPT 2023

Fusion360, Resin 3D Print

0.75 x 0.75 x 1 inches

PROJECT:

Design a custom wearable for a fellow classmate. The design needs to be inspired by the person's interests and preferences. The final deliverable needs to utilize the benefits of 3D printing, presented in a one-of-a-kind packaging that reflects the client.

MY APPROACH:

Since the project is a customized item for a client, I conducted a set of interviews to best know my client's desires and preferences. From those interviews, I iterated designs for various types of jewelry and aesthetics. A couple of abstract sketches were chosen by the client to continue with, which I translated best into a ring. The final deliverable needed to be a 3D printed item, so I wanted to explore the benefits through a more complex CAD model. The model is two rings that interloop, creating a faux stacking effect, as the client emphasized their love for the aesthetic of stacked rings.

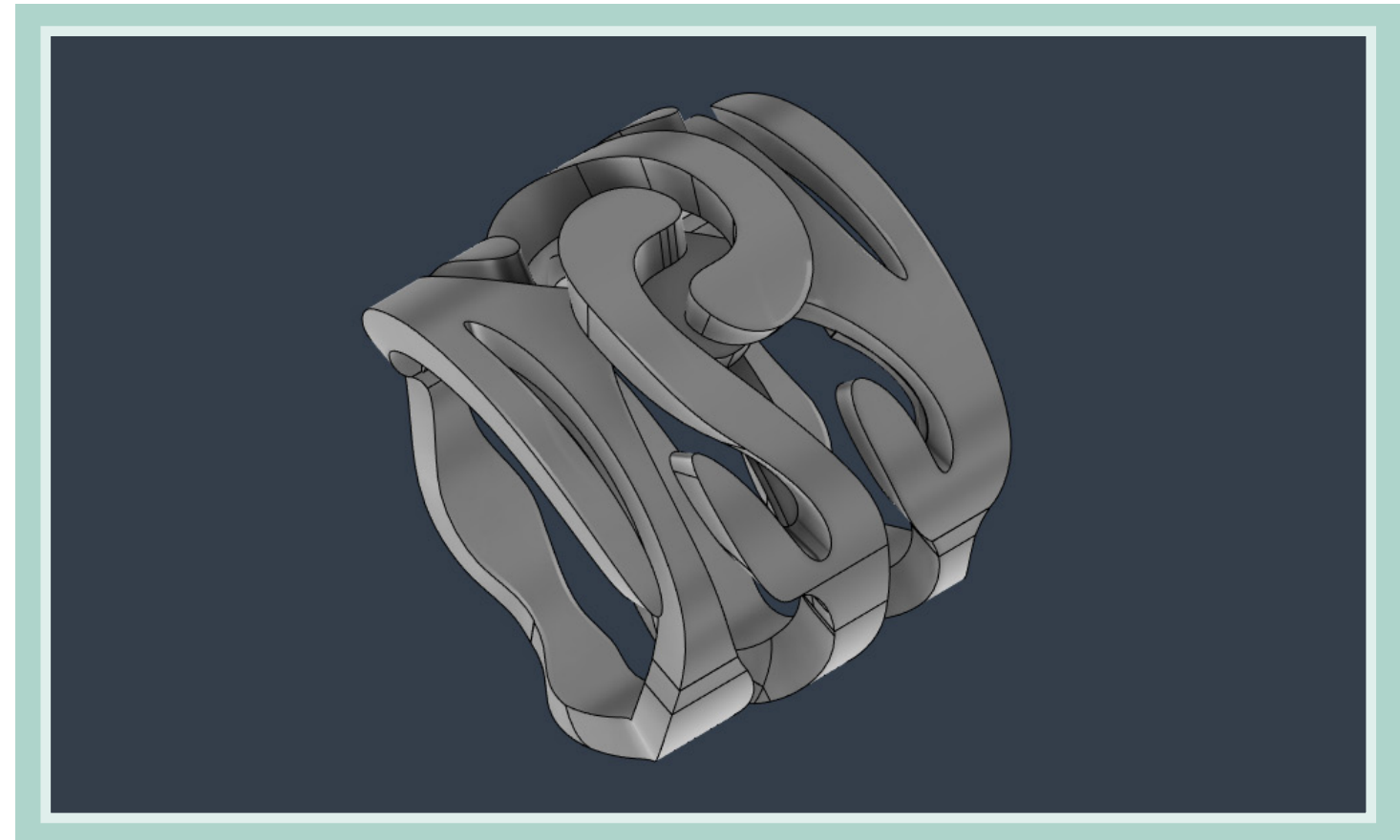

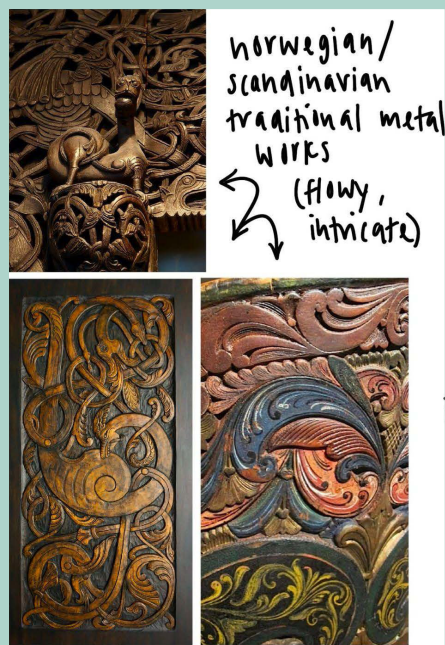
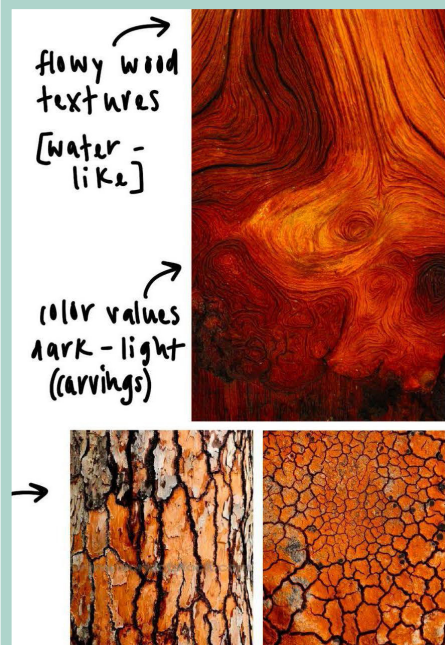

INSPIRATION:

My client expressed a love for wood-working and nature. As a result, I chose to mimic the flowy feeling of wood grain. With family heritage in Norway, and childhood memories of homes with metalwork, the nature detailings were incorporated into the design as an homage.

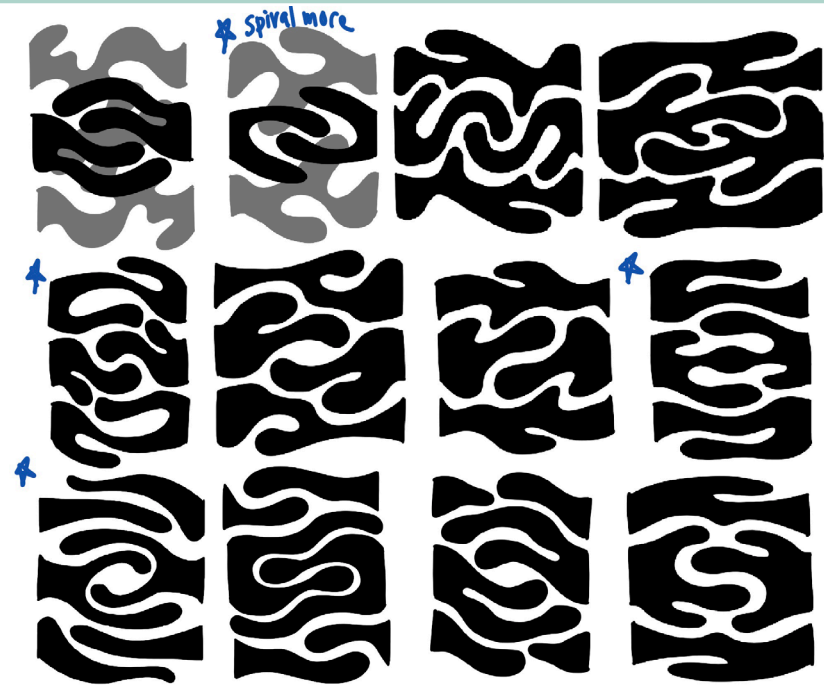

DESIGNING:

The top face has a flowy look of wood knots together with Norwegian nature metalwork. The bottom of the ring (three bands), mimics the crackling of tree bark. The middle band is detached from the others to provide stacking effect.

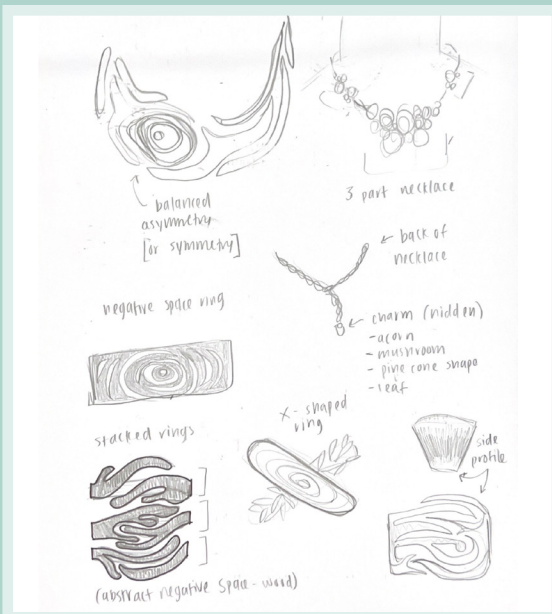

PACKAGING:

The ring box interior was designed to mimic Norwegian metalwork details. I also incorporated my initials in the design to add my touch. The box exterior details also reflect the other jewelry the client normally wears.

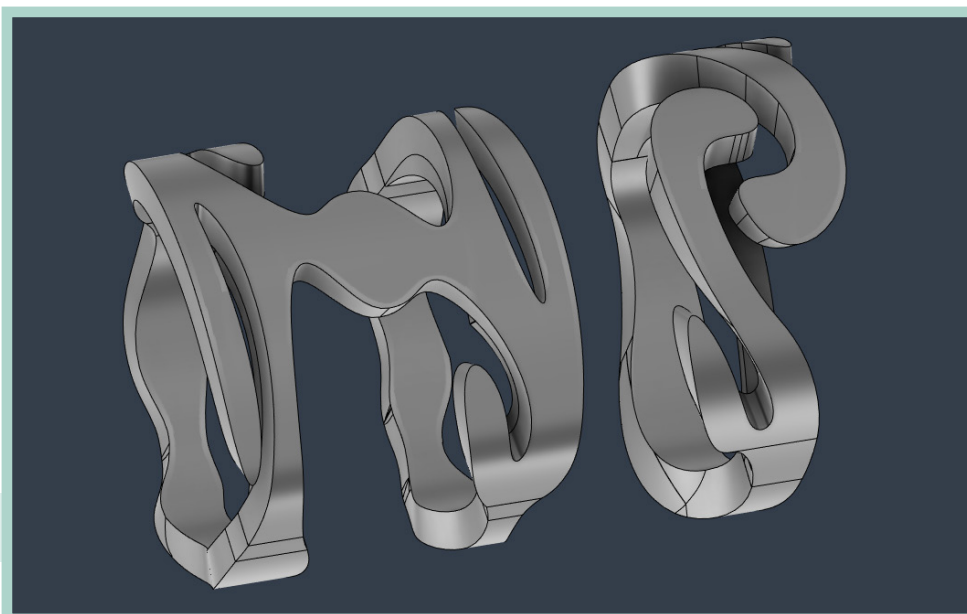
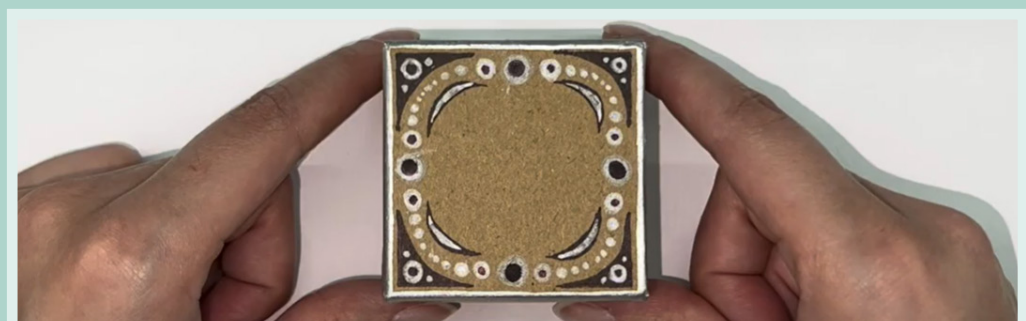

DUOGRIP KID'S TOOTHBRUSH

OCT-DEC 2023

Fusion360, Keyshot, Model-Making

PROJECT:

Research a demographic of your choice and find problem areas they are experiencing. Using that research, find solutions for that demographic that can be solved through product design. Pitch your final design through renders and a case study.

MY APPROACH:

I focused on kids, ages 2-6, as my demographic. I wanted to incorporate my interest in ergonomics, so I specifically researched fine motor skills development. The research highlighted a challenge with learning proper dental care as toddlers. As a result, I expanded my demographic to include parents.

I designed a toothbrush as a teaching tool for parents to show their kids how to properly brush. Also, as a kid-friendly instrument, it empowers them to become more confident in their skill, while bonding with their parents.

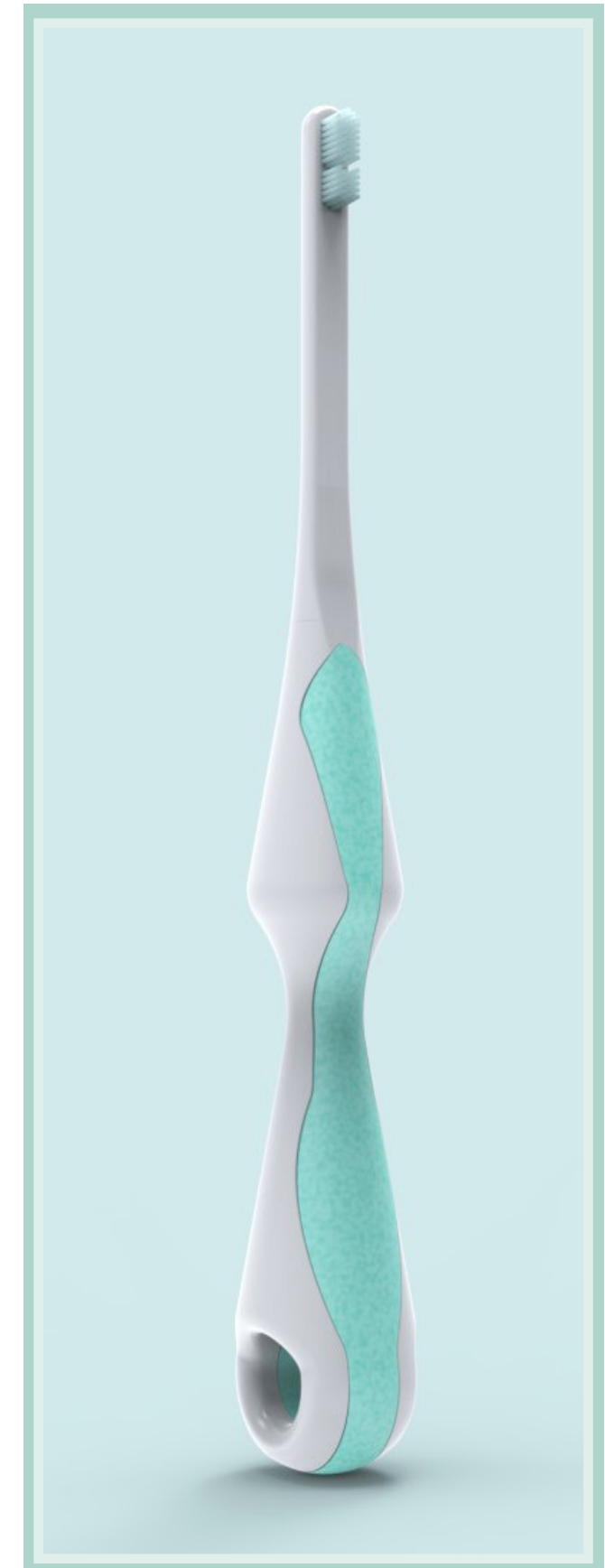
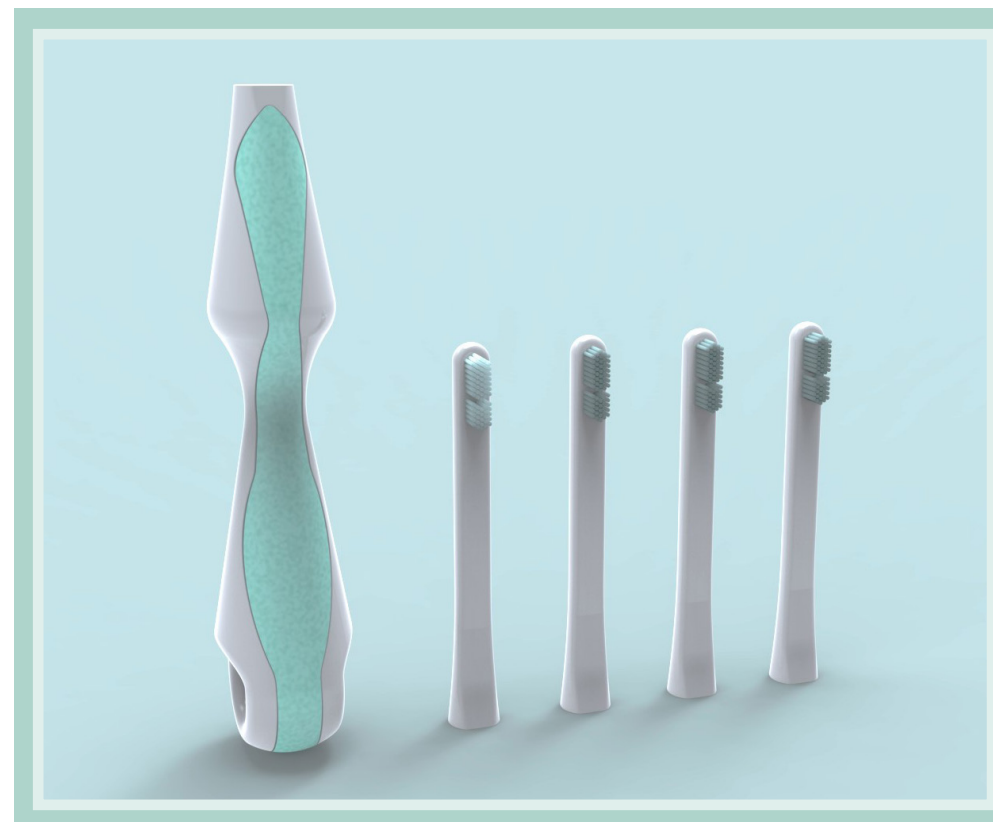

RESEARCH:

The average kids toothbrush is designed with kids' hands in mind, yet they are not meant to brush on their own until they are ready (around 6-8 years old).

Following interviews with multiple families, and the help of secondary research, I decided to explore the idea of designing for both kids and parents.

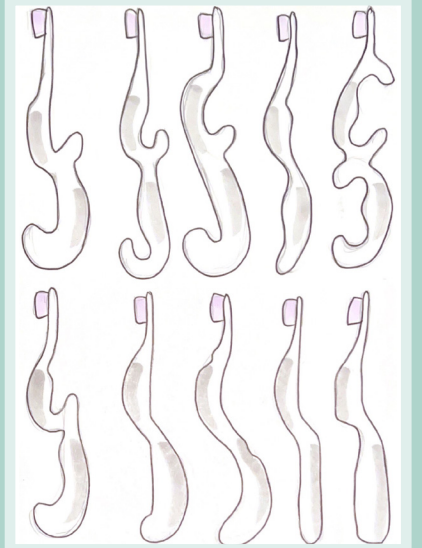
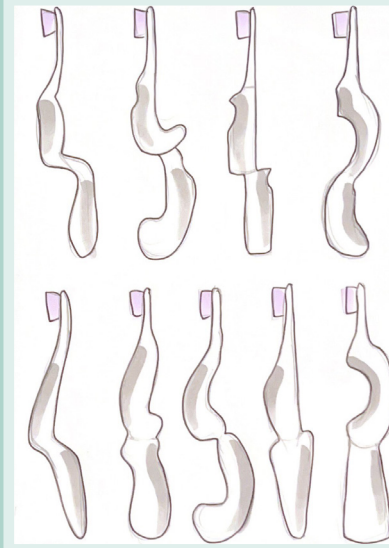
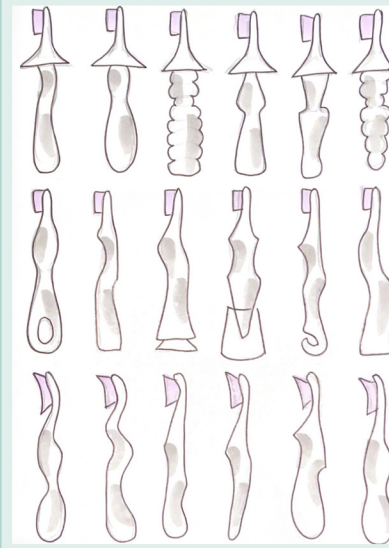
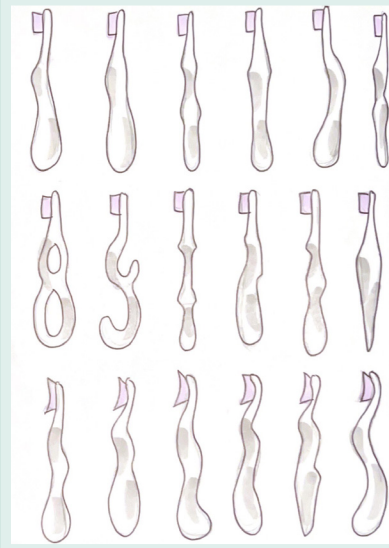

ITERATION:

I came up with the concept of a dual-handle toothbrush that allows a kid and a parent to hold the toothbrush simultaneously. It ensures kids learn how it feels to brush properly, and allows parents properly care for their kid's teeth. The symmetrical grip ensures both users can hold at any angle comfortably. With the changing tips, the kid can grow using this brush until they can brush on their own.

